

# STORAGE SUPPORT SOLUTIONS

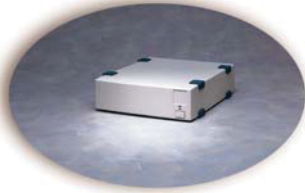

## E301 STACKABLE DRIVE ENCLOSURES

- Provides an external housing solution for a 5.25" or 3.5" drive - SCSI -50 or 68 pin, FIREWIRE, USB2 or fibre channel interfaces available.
- Turnkey solution includes:
  - Dedicated bezel for drive
  - Data cables
  - Drive mounting hardware
- Highest quality on the market
  - First tier covered power supply and fan
  - PDE is ISO 9001
  - 1 year warranty
- Contemporary Design
  - Front mounted power switch
  - Standard logo indent for private labeling
  - Available in black or beige plus custom colors
- Stackable and Convertible
  - All drive types stack with universal footprint
  - Enclosure can sit vertically or horizontally
- Maximum flexibility  
**Can be configured for:**
  - 1/2 height hard drive
  - Low profile hard drive
  - 1/2 height 5 1/4" drive
  - 3.5" tape drive
  - 3.5" zip/jaz drive
- Designed to exceed requirements for 14,000 RPM and LVD Drives

Distributed by:

**Headquarters**  
11522 Markon Drive  
Garden Grove, CA 92841  
Phone:714-799-1704  
Fax:714-799-1705  
E-mail:info@pdetechnology.com

**European Office**  
United Kingdom  
Phone: 44 (0) 1252 879633  
E-mail: info@pdetechnology.co.uk  
Sales E-mail: sales@pdetechnology.co.uk

## COOLING SYSTEM

- 50X50X10 Hi volume cooling fan

### SPECS:

- Size.....50x50x10 mm
- Air Flow....8 CFM
- RPM.....4300
- Power.....0.6 watts
- Sleeve bearing construction
- Locked rotor protection
- 4 pole DC motor design
- UL, CSA, TUV approved

## POWER SYSTEM

- 50 watt auto sensing power supply

### SPECS:

- Input.....100-240
- Size..... L-151mm; W-44mm; H32.5mm
- mtbf 60,000 hours at full load (25°C)
- Short circuit protection with auto recovery
- Over voltage protection with auto recovery
- UL, CSA, TUV approved

Output Voltage	Min	Max	Tolerance	Rippled Noise	Regulation	
					Line	Load
+ 5v	.1A	4.0A	2%	50mv	2%	2%
+ 12v	.1A	3.0A	10%	120mv	2%	10%

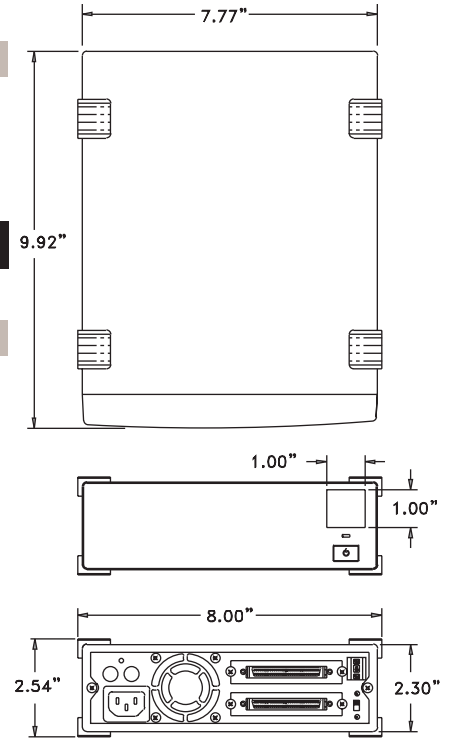

## TESTING PROCEDURE

- Hi Pot
- Voltage
- Cosmetic
- Continuity
- Functionality
- Ground
- Power Supply with Load
- Electrical
- Cooling System
- Mechanical

## PART NUMBERS FOR MODEL E301

- 11-1018 E301 ENCL. FOR 3.5" HDD WIDE
- 11-2007 E301 ENCL. FOR CD WITH HD50 I/O
- 11-1023 E301 ENCL. FOR 5.25" TAPE DRIVE
- 11-1021 E301 ENCL. FOR 3.5" REM. MEDIA NARROW (1" or 1/2 height)
- 11-1019 E301 ENCL. FOR CD WITH C50 I/O
- 11-1020 E301 ENCL. FOR 3.5" REM. MEDIA WIDE
- 11-1022 E301 ENCL. FOR UNIVERSAL DISTRIBUTION (HDD, CD, Tape, bezels inc.)
- Other configurations available

## APPROVALS

Designed to meet FCC and Safety Agency requirements



## SPARE PARTS AND/OR OPTIONS

- Power Supply..... 25-1009
- Fan..... 25-1014
- HDD Bezel..... 22-1099
- CD Bezel..... 22-1071
- 3.5" x 1" open bezel..... 22-1070
- 3.5", 1/2 HT, open bezel..... 22-1072
- Wide (68 pin) data cable,1 drive ..... 29-0036
- Narrow (50P) internal data cable ..... 29-0066
- Wide SCSI ID kit..... 14-1065
- Narrow SCSI ID kit..... 14-1066
- Audio jack kit..... 14-1067
- 68 pin active terminator..... 14-1041
- 68 pin LVD mm terminator..... 14-1025
- C50 pin active terminator ..... 14-1045
- HD50 active terminator..... 14-1043
- 3' external cable HD68m-HD68m..... 29-0029
- 3' external cable HD68m-UHDCI68m.... 29-0098
- 3' external cable HD68m-HD50m..... 29-0095

Weight with packaging Master Carton of 6 pieces is 31.2 lbs.  
OEM/BULK Packaging is available

